



FROST *Fighters*

CLEAN SAFE RELIABLE PORTABLE HEAT

1-888-792-0374 www.frost-fighter.com

IDH1000 FEATURES AND OPERATION MANUAL



Table of Contents

Page 2	-	Fuel Fill Location & Filling Precautions
Page 3-4	-	Door latches, Compartments and Hitch/Tongue Details
Page 5	-	External Power Connections
Page 6 - 8	-	Heater Access Doors and Slide Out System
Page 9	-	Basic Features of Heaters (See heater manual for full operating & servicing information)
Page 10	-	Engine/Generator Layout and Identification (See engine manual for engine type specific detailed information)
Page 11 - 12	-	Rear Compartment Controls & Functions
Page 13	-	Fuel Level Sending Unit
Page 14 - 15	-	Compartment Lighting Control Timers - Function & Adjustment
Page 16	-	Basic Starting Instructions for the Kubota or Isuzu Diesel Engine
Page 17	-	Isuzu Engine Basic Spare Parts List
Page 18	-	Kubota Engine Basic Spare Parts List
Page 19	-	Kubota Engine Oil Requirements
Page 20	-	Location of Rating Plate Information and Serial Number Identification - List of Important Warnings & Precautions
Page 21	-	Optional LED Status Beacon
Page 22 - 24	-	120VAC & 12VDC Standard Circuit Wiring Diagram
Page 25	-	Recommended Maintenance / Service Intervals
Page 26	-	Operating Tips and Specifics
APPENDIX A	-	Overall Exterior Dimensions

Fuel Fill Point

The fuel tank is filled on the side of unit near the rear.

Maximum fuel tank capacity is 190 US gal (718 Litres)

Caution: Do not fill tank above 95% of maximum capacity to allow for fuel expansion.

Refer to rating plate in rear compartment for specific details.

Approximate maximum run time for IDF1000 with full tank is approx. 30 hours.



EXTERIOR FUEL FILL AREA LIGHT

Activated with compartment light button located on main control panel

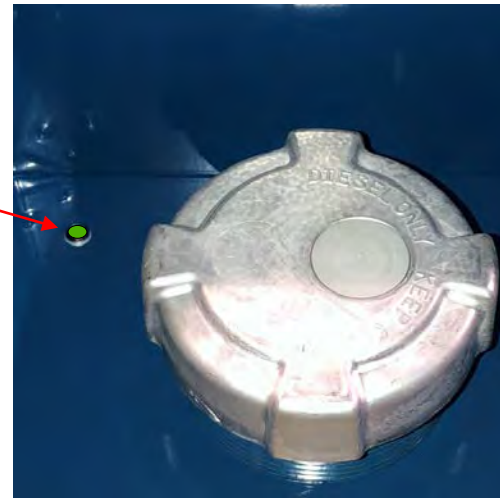

FUEL LEVEL FILL WARNING INDICATOR

This indicator can assist with eliminating the risk of overfilling or splash-back.

- Green LED begins flashing when fuel level reaches 75% of full tank capacity
- Green LED illuminates steady when fuel level reaches 85% to 90% of full tank capacity

(Engine must be stopped and key switch must be ON to activate this feature)

CAUTION:

Filling the fuel tank too quickly or overfilling the tank can increase the risk of spills, backsplash or fuel discharging from the tank vent or fill point due to fuel expansion, etc.

Positive Lock Access Door Latches

Door Latches in Closed Position



Press Bottom of Latches to Open



Trailer tongue area illustrating various components

Left front storage compartment access door.

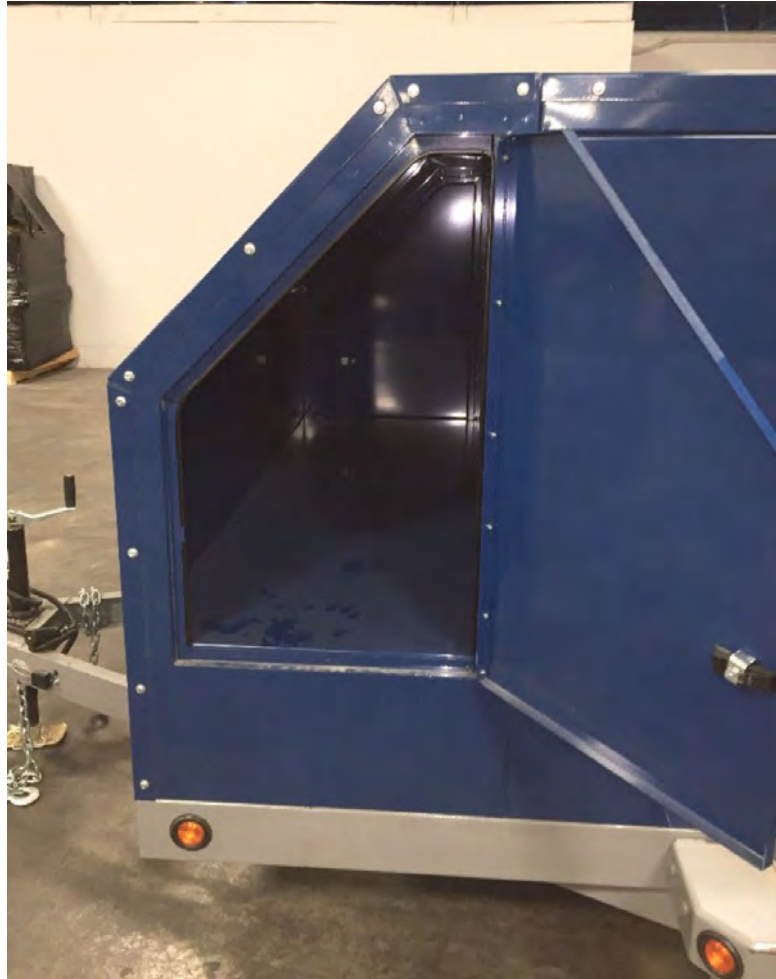

Always ensure tow vehicle has sufficient tow ratings and reduce speed when towing

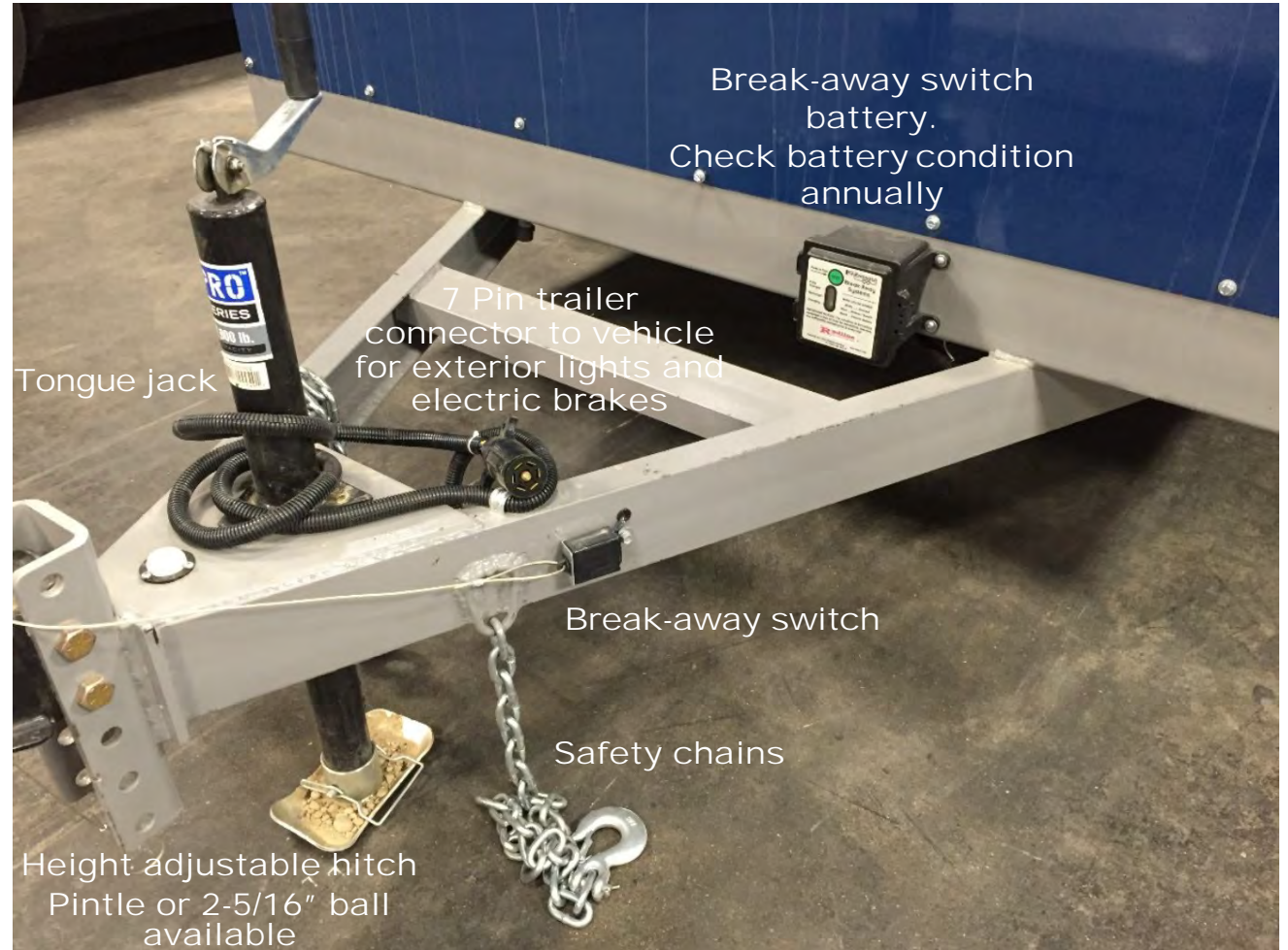

External Power Connections

- 120VAC 15A "shore power" inlet to supply engine block heater and battery charger/maintainer.
- 120VAC 15A GFCI protected auxiliary power outlet



Swing Open Side Access Doors

Access to Heater Discharges

Heater discharge doors have safety interlock switches and each door must be open in order for the respective heater to operate.



Access to Heater Controls

Heater inlet doors provide access to the heater controls and should normally remain open during operation.



Catches are provided to secure doors in the open position

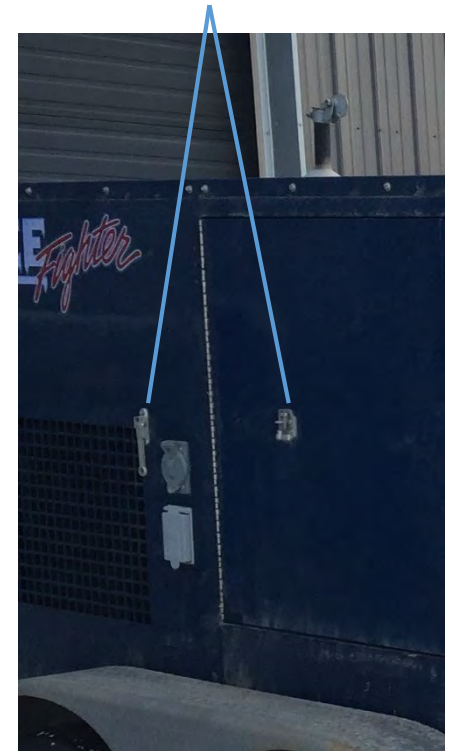

Heaters are mounted onto poly lined slides rails permitting slide out access for service or complete removal from enclosure.

IDH500QR heaters can slide out toward the burner end only and IDF500HS heaters can slide out from both the burner end or the air discharge end.

Illustration of "Lock Bolts" which secure slide rails in locked position. These must be removed in order to slide heaters)into service position



Illustration of a heater pulled into access positions.

Heater travel is limited by "slide limit stop bolts". The heaters can be completely removed from the enclosure by unfastening the slide limit safety stop bolt.

Note: IDH models slide-out from the burner side of the trailer only & require lifting of the clearance cover.



OPENING CLEARANCE COVER TO SLIDE OUT HEATERS



IDH500QR HEATER SHOWN



IDF500HS and IDH500QR Heaters

Burner Controls and Functions

See heater manual for complete operation and maintenance information

PRESSURE GAUGE
KEEP VALVE CLOSED DURING NORMAL OPERATION & OPEN TO ONLY TO CHECK PRESSURE.

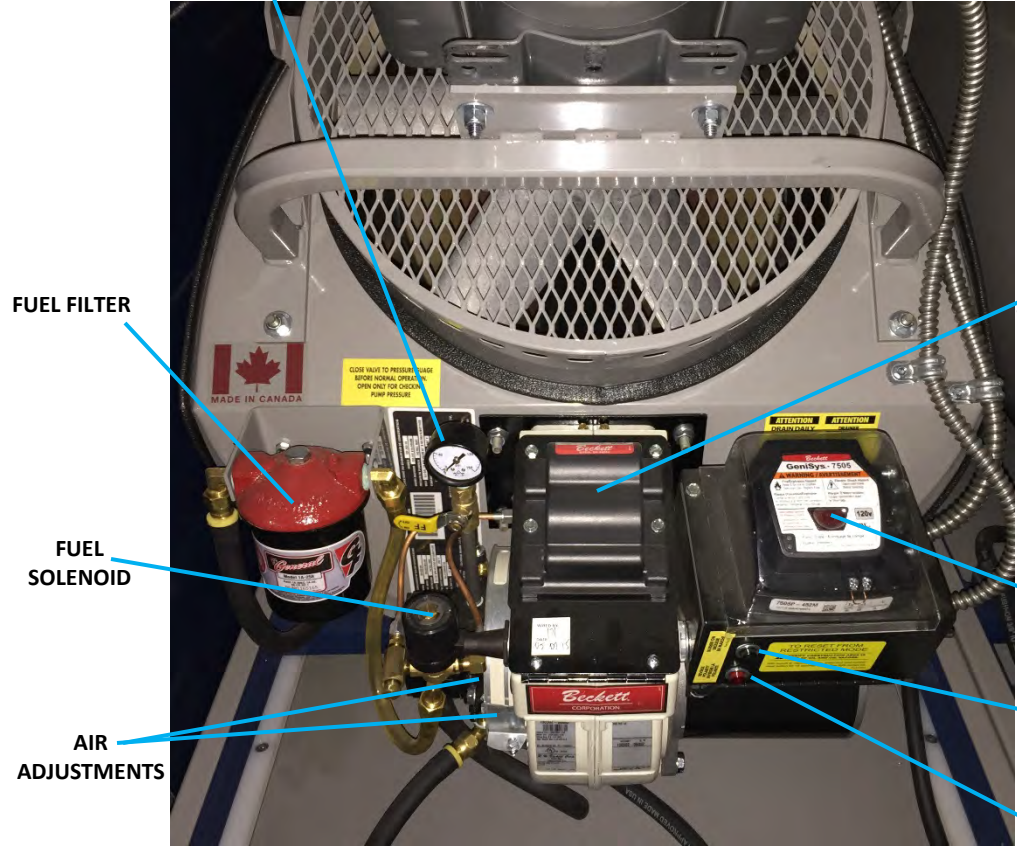

GENISYSY 7505 CONTROL

BURNER CIRCUIT BREAKER

IGNITION TRANSFORMER

BURNER OPERATION SELECTOR SWITCH. OFF / MANUAL / THERMOSTAT

GENISYS CONTROL RED "LOCKOUT" INDICATOR AND RESET BUTTON

FUEL SOLENOID VALVE "ENERGIZED" INDICATOR

POWER SUPPLY INDICATOR



REMOTE THERMOSTAT CONNECTION

Diesel Generator

KUBOTA ENGINE UNIT

Refer to Engine Manual for Instructions and Servicing

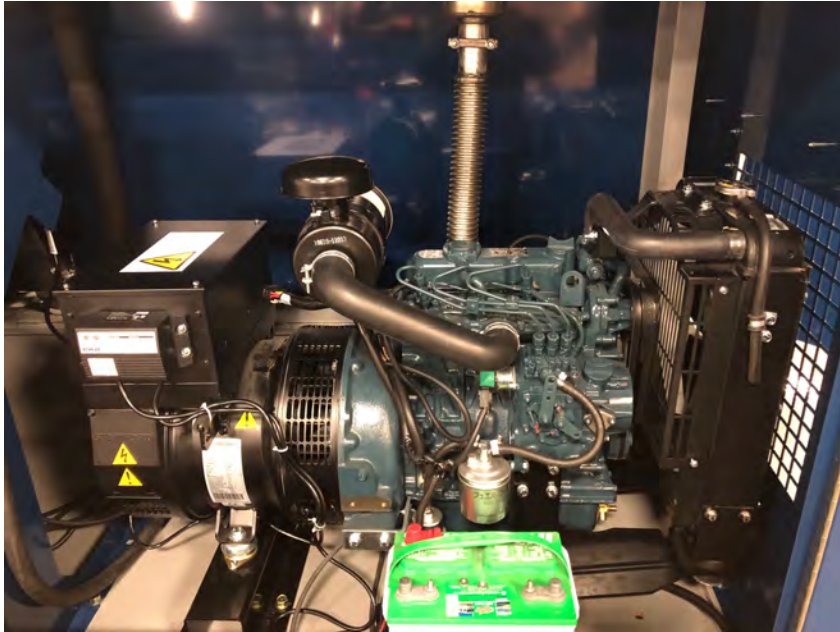

ISUZU ENGINE UNIT

Refer to Engine Manual for Instructions and Servicing

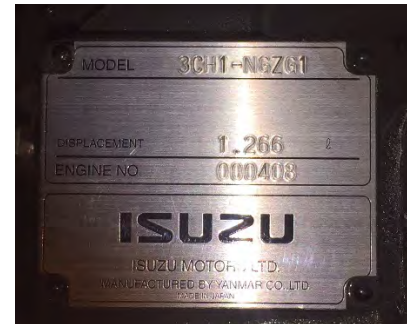
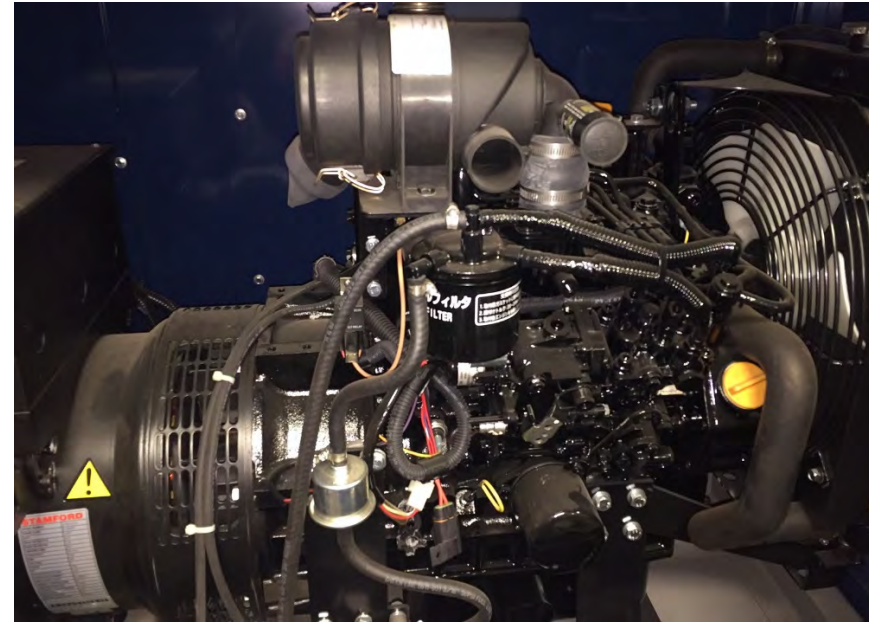

Rear Compartment Power Distribution and Controls

Control functions for both Kubota & Isuzu engine versions are similar.

Individual Circuit Breakers for main supply power and each heater and the auxiliary power receptacle.

Fuel gauge shows fuel level when engine is running or keyswitch is in accessory position.

Power meter indicates volt, amp, kilowatts or HZ (selectable))when generator is running.



POWER METER

DISPLAY SCREEN

INDICATES SUPPLY VOLTAGE, TOTAL AMPS, TOTAL WATTS OR LINE FEQUENCY



INDICATOR LIGHTS

ILLUMINATES TO SHOW WHAT IS BEING MEASURED & DISPLAYED

SELECTOR BUTTON

ALLOWS USER TO SELECT WHAT VALUE TO READ OR CAN BE SET TO SCROLL

Momentarily pressing "SEL" button each time will cycle the display to the next measurement.

Holding the "SEL" button for 3 seconds will set the meter to continuously cycle through each measurement and display them for 3 seconds.

The meter can also be configured to always display the desired specific measurement such as amps or watts each time the heater is powered up. This is accomplished by setting the meter to the desired measurement reading and leaving it to display that reading without touching the "SEL" button for at least 60 seconds. Then each time the unit is powered up it will display that measurement.

NOTE:

DISPLAY MAY INDICATE A RUNNING FEQUENCY ABOVE 60 HZ. (62HZ-64HZ). THIS IS NORMAL TO ALLOW FOR ENGINE SPEED DROOP OF THE GOVENOR AND PREVENT THE FRQUENCY FROM DROPPING BELOW 60 HZ. WITH FULL ENGINE LOADS.

Pushbuttons for Compartment Lighting and Accessories

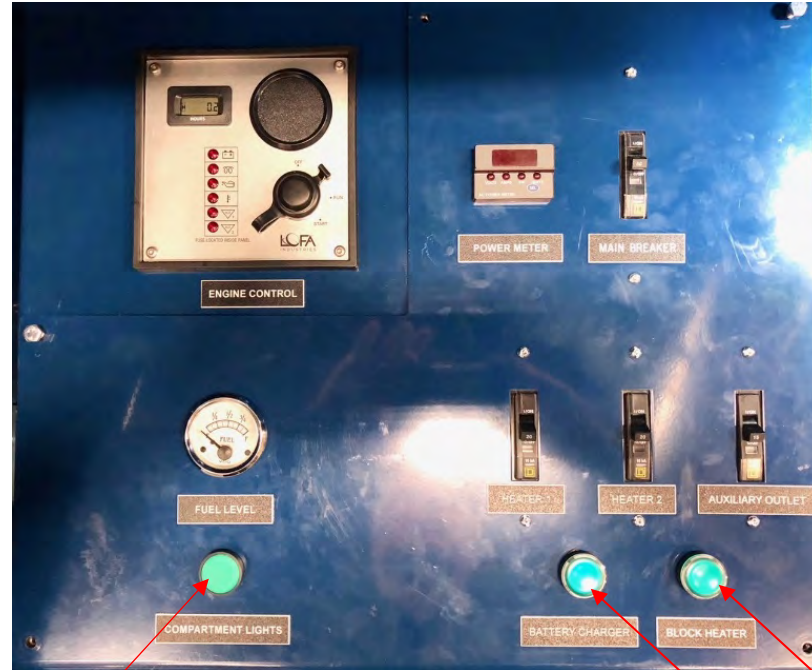

Compartment Lights

- Press button to activate compartment lights & fuel fill area light.
- Lights will remain on for 3 minutes & will then automatically turn off.
- Press & hold button for 2 seconds when activating lights for lights to remain on for 20 minutes & then automatically turn off. Lights will briefly flash after holding the button to indicate the 20 minute time has been activated.
- Press button at anytime to turn lights off before the timing period has completed.

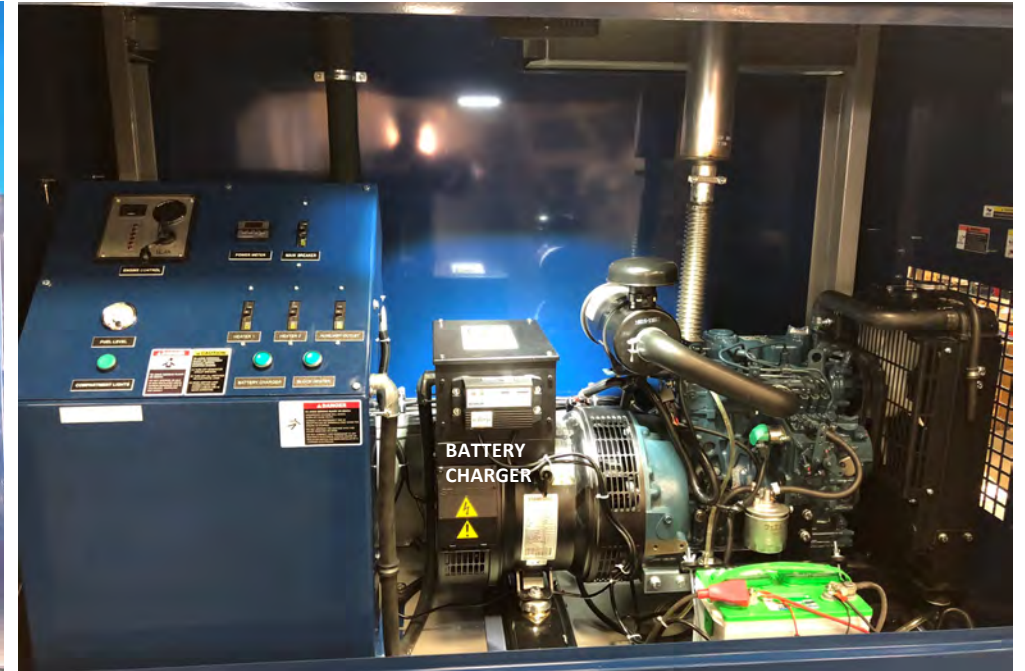

Battery Charger & Block Heater

Battery charger & block heater buttons are push-on/push-off
Press buttons to activate & button will illuminate when power is supplied Press buttons again to deactivate.

These buttons and the devices they activate are functional only when an external power source is supplied through the "120V POWER IN" exterior inlet receptacle.

Fuel Level Sending Unit

33-240 ohm. Linear Reed Switch Fuel Level Sender



IDH1000 models after July 2019 utilize a sealed linear type fuel sender that does not require any adjustment.

These are not interchangeable with the previous 10-180 ohm. adjustable type.
If you require a fuel sender for earlier models please call your dealer or Frost Fighter for the correct part.

Compartment Lighting Timers

- **Compartment lighting is controlled with a programmable PLC control activated with the momentary pushbutton on the panel. This prevents unwanted battery drain from constant unattended operation of the lights.**
- The PLC has two pre-programmed timing periods of 3 minutes or 20 minutes depending on the lighting duration desired. Selecting the desired lighting times is described on page 12.
- The PLC is located under the front control panel and has a display screen that can be used for operation information, troubleshooting and programming.
- The control also has a 6 pin receptacle on the exterior left rear of the control panel that is designed for connection to an optional Frost Fighter LED roof beacon. This 3 color high intensity beacon can be used to display operational status and alerts for low fuel levels. See page 20.



CAUTION RISK OF ELECTRIC SHOCK

ENSURE 120VAC EXTERNAL POWER IS DISCONNECTED AND/OR GENERATOR IS STOPPED BEFORE ACCESSING THE CONTROLS AND CHANGING TIMER SETTINGS.

Gaining Access to PLC Control and Low Voltage Fuses

TO OPEN, REMOVE THE FIVE FRONT PANEL BOLTS AND LIFT THE FRONT COVER TO ACCESS THE FUSES AND PLC CONTROL

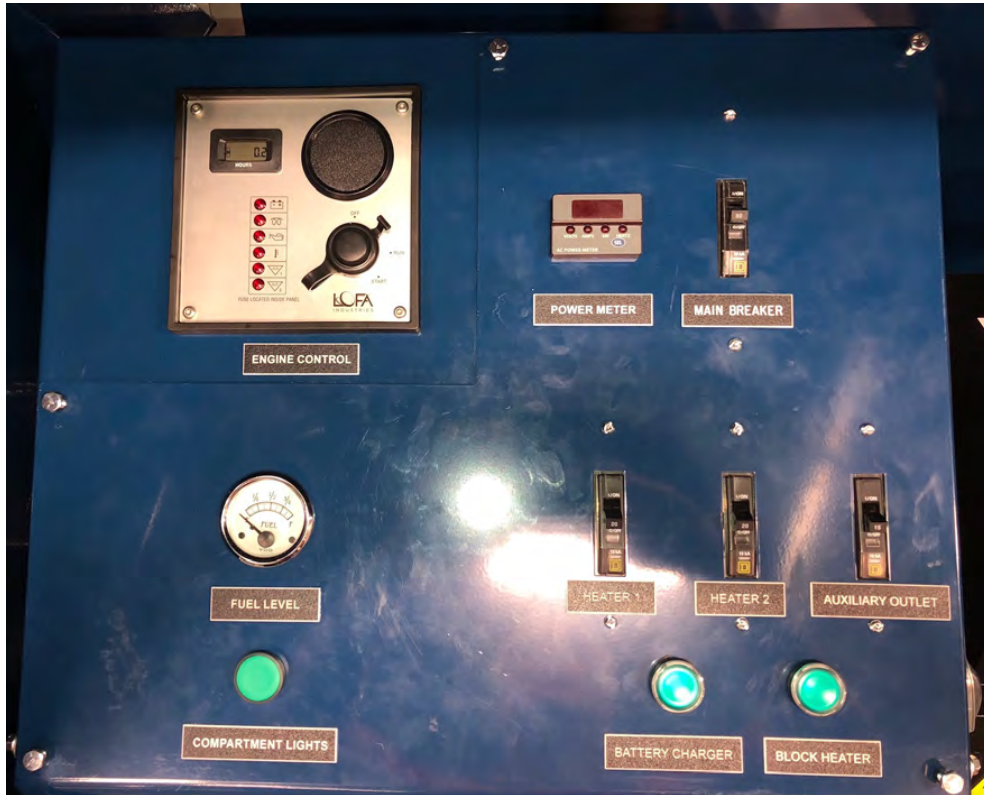

Fuses for 12VDC power are located inside control panel
One 10 amp & three 1 amp ATO fuses



Fuse for 120VAC power meter inside panel as shown
1 amp AG 250V

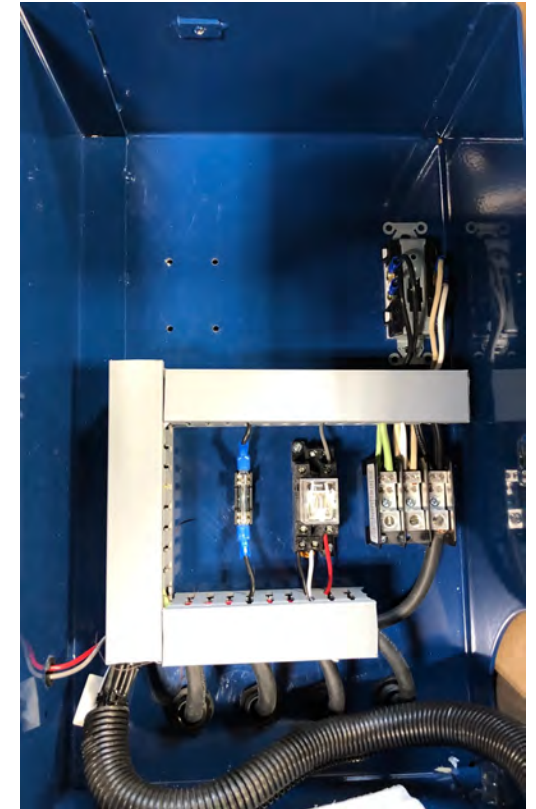

CAUTION RISK OF ELECTRIC SHOCK

ENSURE 120VAC EXTERNAL POWER IS DISCONNECTED AND/OR GENERATOR IS STOPPED BEFORE ACCESSING THE CONTROLS AND CHANGING TIMER SETTINGS.

Starting the diesel engine

Turn key-switch on LOFA control from "OFF" to "RUN" position.

LOFA control shown with key-switch placed in "RUN" position which illuminates the indicator lights & activates the fuel gauge.

The electric fuel pump for priming will operate for approx. 10 seconds. Turn the key-switch to "OFF" & then back to "RUN" to reactivate electric fuel pump for additional 10 sec. if extended priming is required or engine fails to start.



After a few seconds with the key-switch in the "RUN" position the lower indicator lights will go off.

Engine preheating is shown by the illuminated "PREHEAT" indicator light and will remain on until preheating is complete.

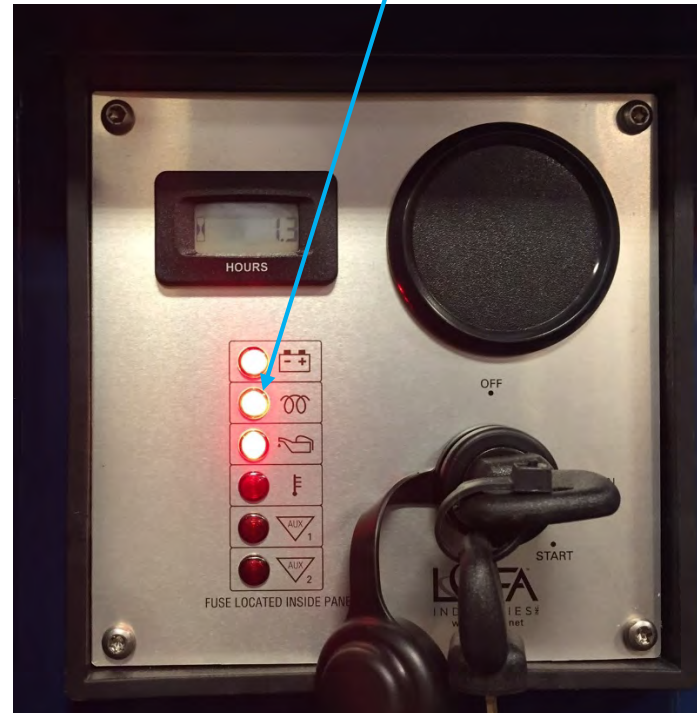

When the "PREHEAT" indicator light goes off move the key-switch to "START" and release once engine starts.

If the engine starts but fails to run or it fails to start then repeat this process.

To stop the engine move key-switch to the "OFF" position



IMPORTANT: DO NOT STOP THE ENGINE/GENERATOR UNTIL BOTH HEATERS HAVE BEEN SHUT DOWN FIRST AND HAVE COMPLETED THEIR COOL DOWN CYCLE AND THE FANS HAVE STOPPED.

Industrial Diesel Engine

Kubota 05 Series D1305-E4B



PERFORMANCE CURVE

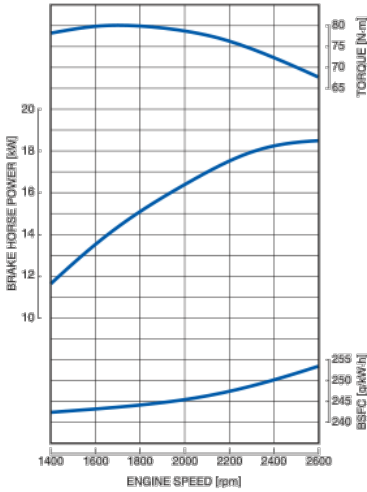

GENERAL SPECIFICATION		
Model	D1305-E4B	
Emission Regulation	Tier 4	
Type	Vertical 4-cycle Liquid Cooled Diesel	
Number of Cylinders	3	
Bore	mm (in)	78.0 (3.07)
Stroke	mm (in)	88.0 (3.46)
Displacement	L (cu.in)	1.261 (76.95)
Combustion System	IDI	
Aspiration	Naturally Aspirated	
Operating Speed	rpm	1800
Output: Gross	kW	14.2
	HP	19.0
Direction of Rotation	Counterclockwise Viewed on Flywheel	
Oil Pan Capacity	L (U.S.gal)	5.7 (1.51)
Starter Capacity	V-kW	12-1.2
Alternator Capacity	V-A	12-40
Length	mm (in)	503.5 (19.82)
Width	mm (in)	374.4 (14.74)
Height (1)	mm (in)	590.1 (23.20)
Height (2)	mm (in)	215.6 (8.49)
Dry Weight	kg (lb)	95.0 (209.4)

DIMENSIONS

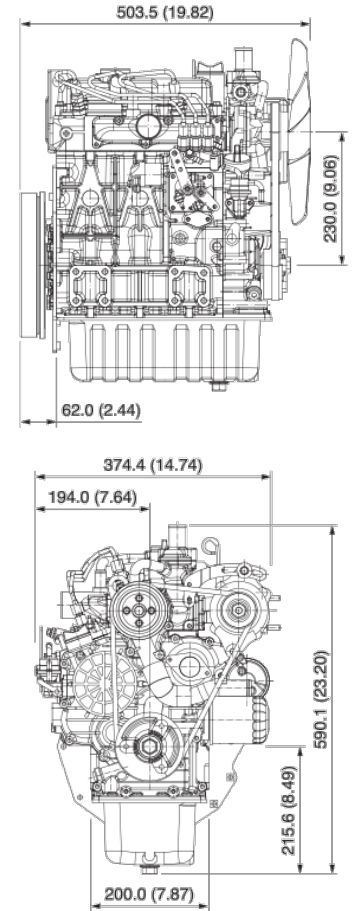

*Specification is subject to change without notice.

*Dry weight is according to Kubota's standard specification.

SPARE PARTS LIST FOR KUBOTA D1305 ENGINE

DESCRIPTION	PART NUMBER	CROSS REFERENCE PART NUMBER
Oil Filter	HH160-32093	BALDWIN B161-S / FLEETGUARD LF3536 / WIX 51064
Fuel Filter	70000-43080	Donaldson P550127 / Baldwin FFR-P4766 (Spin-on) WIX 33830 (cartridge)
Air Cleaner Element	15741-11080	Baldwin PA3476 / LUBERFINER LAF8823 / WIX 49410 (WA10015 Outer)
Valve Cover gasket	1G700-14520	
Alternator	16231-64012	
Starter	6A230-59210	
Thermostat	19434-73014	
Thermostat Gasket	16221-73270	
Water Pump	16251-73034	
Water Pump Gasket	16239-74014	
Fan Belt	16282-97013	
Stop Solenoid	17208-60016	

ISUZU MOTORS AMERICA, LLC PowerTrain Division		MODEL ISZJ SPEC NO. DWG NO./DATE	3CH1NGZG1 IS-15-098-0 B3-19E46-0020, N/A	
BASIC ENGINE DESCRIPTION	1.3L, 3 CYL, 4 STROKE, WTR COOLED, OHV, I/L, INDIRECT INJECTED, NATURALLY ASPIRATED DIESEL B:80mm, S:84mm, CR:23.1:1, GLOW PLUG ASSISTED START			
ENGINE CONFIGURATION	INDUSTRIAL F/F GENSET ENGINE 12V US EPA (Final Tier 4) CERTIFIED & EC EXEMPT (<19kW)	ENGINE PERFORMANCE*	14.3 BHP@1800 RPM (STANDBY) 13.0 BHP@1800 RPM (PRIME) LOW IDLE SPEED: 1800±25 RPM HIGH IDLE SPEED: 1925±25 RPM	
SPECIFIC OEM INFORMATION	ISZA STD	DATE OF ISSUE:	7/22/2016 ISZA	DATE RELEASED: 7/22/2016 ISZA PREVIOUS ISSUE DATE:
SPECIFICATION INFORMATION				
PART NAME	PART NUMBER	TYPE	PART DESCRIPTION	
CRANKCASE BREATHER	N/A		CLOSED TYPE; INTEGRAL PART OF INLET MANIFOLD	
FLYWHEEL HOUSING	5-86400-948-0		SAE#5, t:124mm, w/TACHPORT 3/4"-16@45° CCW FROM 3 O'CLOCK	
OIL PAN	5-86400-756-0		3.4L MAX, 1.6L MIN, ANGLED 30° ALL DIR, BOTTOM DRAIN	
DIPSTICK	5-86400-708-0		SHORT TYPE	
FLYWHEEL	5-86402-455-0		SAE 7.5", w/DRIVE RING Z:116	
CRANKSHAFT PULLEY	5-86402-457-0		EFF DIA:110mm	
OIL FILTER	5-86400-632-0		TOYO ROKAKI, FULL FLOW PAPER ELEM TYPE DONALDSON P502067	
FUEL FILTER	5-86401-996-0 5-86400-776-0	ASM ELEM	TAIYOGIKEN, PAPER ELEM TYPE, CARTRIDGE TYPE Spin-on Donaldson P550048 Donaldson P50-2166 element	
WATER PUMP	5-86402-032-0		IMPELLER TYPE, LOW POSITION, w/HOT HEATER PLUG	
WATER OUTLET PIPE	5-86400-909-0		LH SIDEWARD	
THERMOSTAT	5-86400-718-0		71°C INITIAL OPENING TEMP AT ATMOSPHERIC PRESSURE; 85°C TEMP AT VALVE LIFT OF 8mm & OVER	
COOLING FAN	5-86400-913-0		335mm DIA, PULLER, 6-BLADE, PLASTIC	
FAN PULLEY	5-86400-716-0		EFF DIA:100mm RATIO:1.1:1 FAN BELTA-36	
FAN SPACER	5-86400-287-0		t=25mm	
BOLT, FAN FIXING	5-86400-572-0		QTY 4, M6 x 35mm	
OIL COOLER	N/A			
INLET MANIFOLD	N/A		RH SIDEWARD (COMBINED w/HEAD COVER)	
AIR CLEANER (Filter)	N/A		DONALDSON P822686	
INTAKE AIR HEATER	N/A			
*Rating: SAE J1349 NET without Fan				

With strict emission control regulations now in effect, the CF-4 and CG-4 engine oils have been developed for use with low sulfur fuels, for On-Highway vehicle engines. When a Non-Road engine runs on high sulfur fuel, it is advisable to use a "CF or better" classification engine oil with a high Total Base Number (a minimum TBN of 10 is recommended).

● **Lubricating oil recommended when a low-sulfur or high-sulfur fuel is employed.**

○ : Recommendable × : Not recommendable

Lubricating oil classification	**Fuel		Remarks
	Low-sulfur	High-sulfur	
CF	○	○	*TBN \geq 10
CF-4	○	×	
CG-4	○	×	
CH-4	○	×	
CI-4	○	×	

*TBN: Total Base Number

**Fuel

- Diesel Fuel Specification Type and Sulfur Content % (ppm) used, must be compliant with all applicable emission regulations for the area in which the engine is operated.
- Use of diesel fuel with sulfur content less than 0.10 % (1000 ppm) is strongly recommended.
- If high-sulfur fuel (sulfur content 0.50 % (5000 ppm) to 1.0 % (10000 ppm)) is used as a diesel fuel, change the engine oil and oil filter at shorter intervals. (approximately half).
- DO NOT USE Fuels that have sulfur content greater than 1.0 % (10000 ppm).
- Since KUBOTA diesel engines of less than 56 kW (75 hp) utilize EPA Tier 4 and Interim Tier 4 standards, the use of low sulfur fuel or ultra low sulfur fuel is mandatory for these engines, when operated in US EPA regulated areas. Therefore, please use No.2-D S500 or S15 diesel fuel as an alternative to No.2-D, and use No.1-D S500 or S15 diesel fuel as an alternative to No.1-D for ambient temperatures below -10°C (14°F).
1) No.1-D or No.2-D, S500 : Low Sulfur Diesel (LSD) less than 500 ppm or 0.05 wt.%
No.1-D or No.2-D, S15 : Ultra Low Sulfur Diesel (ULSD) 15 ppm or 0.0015 wt.%
- CJ-4 classification oil is intended for use in engines equipped with DPF (Diesel Particulate Filter) and is Not Recommended for use in Kubota E3 specification engines.
- Oil used in the engine should have API classification and Proper SAE Engine Oil according to the ambient temperatures as shown below:

Above 25°C (77°F)	SAE30, SAE10W-30 or 15W-40
0 to 25°C (32°F to 77°F)	SAE20, SAE10W-30 or 15W-40
Below 0°C (32°F)	SAE10W, SAE10W-30 or 15W-40

● Recommended API classification

Refer to the following table for the suitable American Petroleum Institute (API) classification of engine oil according to the engine type (with internal EGR, external EGR or non-EGR) and the Fuel Type Used : (Low Sulfur, Ultra Low Sulfur or High Sulfur Fuels).

Fuel type	Engine oil classification (API classification)	
	Engines with non-EGR Engines with internal EGR	Engines with external EGR
High Sulfur Fuel [0.05 % (500 ppm) ≥ Sulfur Content < 0.50 % (5000 ppm)]	CF (If the "CF-4, CG-4, CH-4 or CI-4" engine oil is used with a high-sulfur fuel, change the engine oil at shorter intervals. (approximately half))	---
Low Sulfur Fuel [Sulfur Content < 0.05 % (500 ppm)] or Ultra Low Sulfur Fuel [Sulfur Content < 0.0015 % (15 ppm)]	CF, CF-4, CG-4, CH-4 or CI-4	CF or CI-4 (Class CF-4, CG-4 and CH-4 engine, oils cannot be used on EGR type engines.)

EGR: Exhaust Gas Re-circulation

IMPORTANT WARNINGS AND PRECAUTIONS

Rating Plate Information and Serial Number Located
on inside wall of Generator/Control Compartment

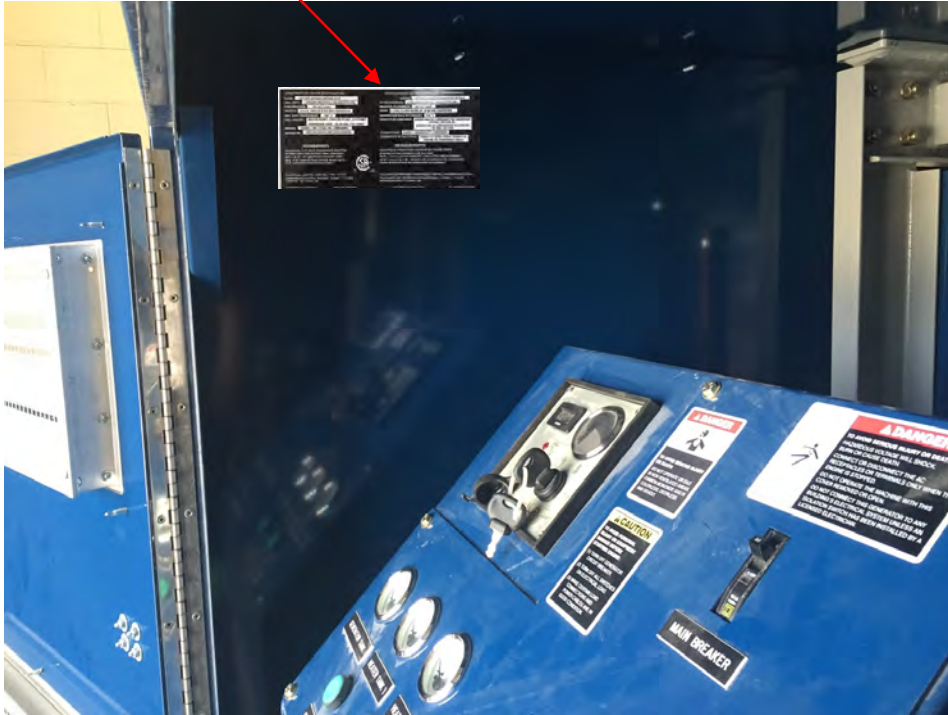

UNDERSTAND AND OBSERVE ALL RULES AND PRECAUTIONS REGARDING THE TOWING OF A TRAILER & USE AN APPROPRIATELY RATED AND EQUIPPED TOW VEHICLE

ENSURE THAT ALL MINIMUM CLEARANCES STATED ON THE RATING PLATE ARE MAINTAINED DURING OPERATION

**CAUTION MUST BE TAKEN DURING REFUELLING TO ELIMINATE THE POSSIBLE RISK OF A SPARK OR FIRE & AVOID FUEL SPILLAGE
USE ENVIRONMENTAL SPILL TRAYS UNDER THE FUEL FILL POINTS WHENEVER POSSIBLE OR WHEN REQUIRED**

**RISK OF ELECTRIC SHOCK PRESENT
DO NOT REMOVE OR DISABLE ANY GROUNDING
DO NOT HANDLE LIVE ELECTRICAL CORDS OR CONNECTIONS WHILE STANDING ON WET SURFACES.**

THIS EQUIPMENT IS FOR OUTDOOR USE ONLY - ENSURE ADEQUATE VENTILATION IS PROVIDED TO THE UNIT

AVOID LOCATING THIS EQUIPMENT WHERE THERE MAY BE A RISK OF CARBON MONOXIDE ENTERING AREAS WHERE PERSONS ARE WORKING OR PRESENT SUCH AS DIRECTLY AT DOORWAYS OR LARGE OPENINGS

THIS EQUIPMENT SHOULD ONLY BE OPERATED BY PERSONS FAMILIAR WITH THE SAFE OPERATION OF THIS TYPE OF EQUIPMENT.

Optional High Intensity LED Roof Beacon



*UL (US/Can) Approved
IP65 Weatherproof - RoHS Compliant*



*Beacon Displays Steady Amber when
Keyswitch is On But Generator is not
Supplying 120VAC*



*Beacon Displays Steady Green when
Generator is Operating and Supplying
120VAC*



*Steady Red Indicates Low Fuel
Red Flashing Indicates an alarm state
(Heater Lockout)
Fast Flash rate is selectable at 80/min. or 240/min.*



*Connector Mounted On Rear of Main Control
Panel Permits Fast And Simple Connection Of
Beacon*



*Optional 5" Extension Tower
Improves Line of Sight and
Includes Fold Down Feature*



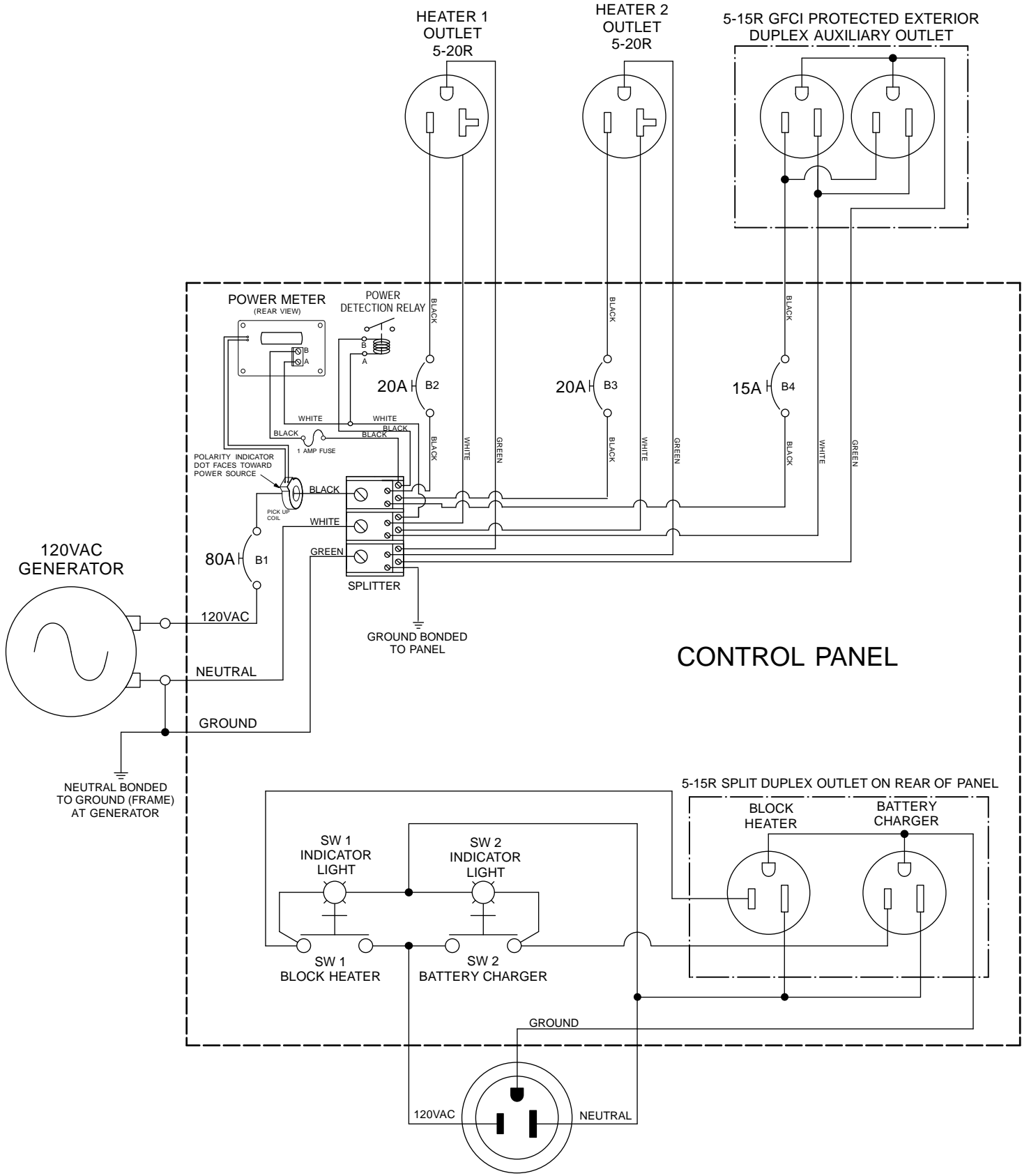

CONTROL PANEL



**120VAC
CIRCUIT DIAGRAM**

PROPRIETARY AND CONFIDENTIAL
 THE INFORMATION CONTAINED IN THIS DRAWING IS THE SOLE PROPERTY OF FROST FIGHTER INC. ANY REPRODUCTION IN PART OR AS A WHOLE WITHOUT WRITTEN PERMISSION OF FROST FIGHTER INC. IS PROHIBITED

MATERIAL	N/A	DRAWN	E.H.
CUSTOMER		DESIGNED	
TOLERANCES		DATE	16/08/19
X.X	±.1 FRACTIONS	SCALE	N/A
±1/32			
X.XX	±0.2 DRAFT ANGLE 3°		
X.XXX	±.005 RADIUS 1/8		

SIZE	MODEL#	REV
A	IDH1000 / IDF1000	3

IDH1000 12VDC CIRCUIT WIRING

w/ Optional ZTR M6 Telematics Control

CONTROL PANEL

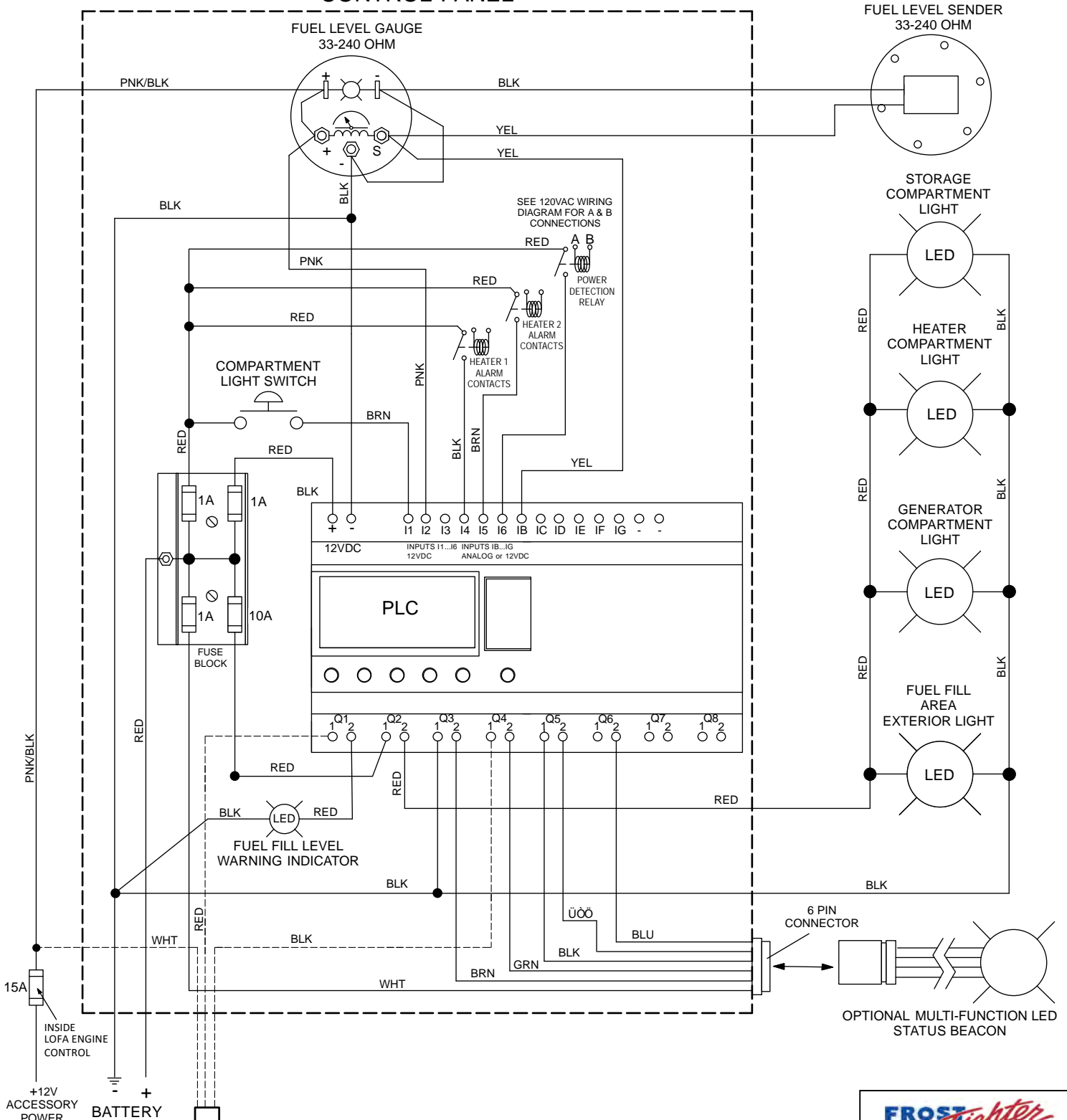

**OPTIONAL
ZTR M6
TELEMATICS
MODULE**

PROPRIETARY AND CONFIDENTIAL
THE INFORMATION CONTAINED IN THIS DRAWING IS THE SOLE PROPERTY OF FROST FIGHTER INC. ANY REPRODUCTION IN PART OR AS A WHOLE WITHOUT WRITTEN PERMISSION OF FROST FIGHTER INC. IS PROHIBITED.

MATERIAL	N/A	DRAWN	E.H.
CUSTOMER		DESIGNED	
TOLERANCES		DATE	7/09/19
X.X	±.1 FRACTIONS	SCALE	N/A
X.XX	±0.2		
X.XXX	±.005		
	DRAFT ANGLE 3°		
	RADIUS 1/8		

FROST
Fighter

**12VDC
CIRCUIT DIAGRAM**

SIZE	MODEL#	REV
A	IDH1000 / IDF1000	4.1

TYPICAL KUBOTA WIRING

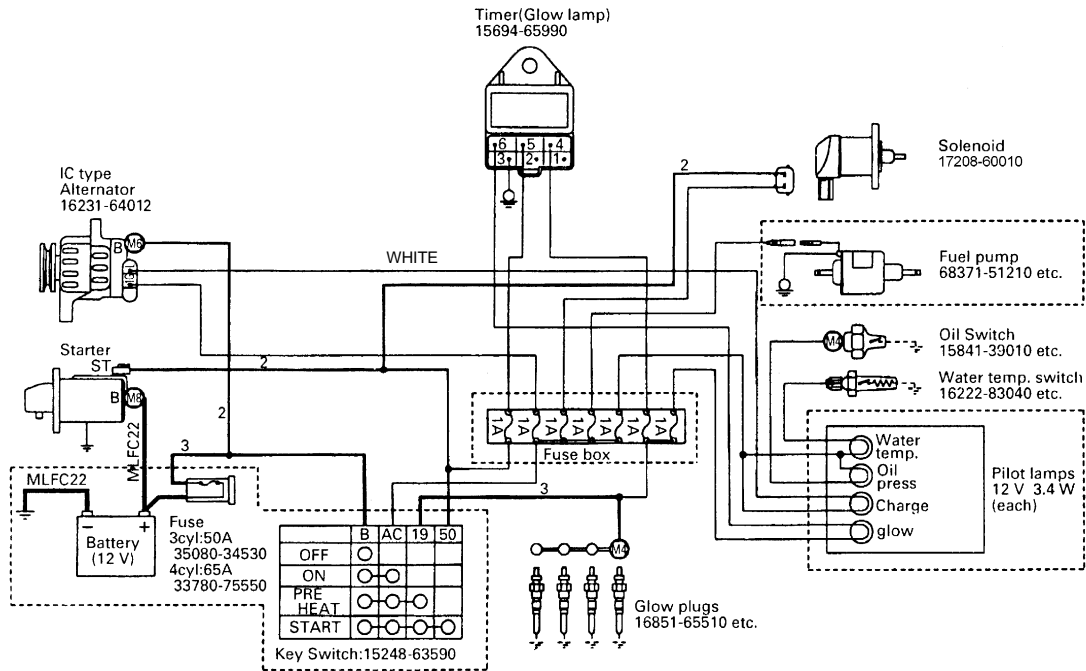

RECOMMENDED MAINTENANCE/SERVICE INTERVALS FOR TRAILER/FUEL TANKS	
INTERVAL	ITEM
Every 50 hours	<ul style="list-style-type: none"> - Check wheel lugnut torque and tire condition - Check trailer lighting and safety breakaway system
Every 100 hours	<ul style="list-style-type: none"> - Check and/or replace heater fuel filter element <i>(See page 23 of heater manual for recommended replacement interval details)</i> - Inspect for any debris or excessive dirt around fan intake & burner air intake - Inspect for any fuel leaks
Every 200 hours	<ul style="list-style-type: none"> - Check heater fuel line condition and connections are secure - Inspect flue pipe and rain cap - Inspect power cords to heaters and all bolts securing heaters - Inspect aux. power outlet receptacle & block heater inlet receptacle - Inspect 120VAC wiring from generator to control panel
Every 500 hours	<ul style="list-style-type: none"> - Inspect burner electrodes/nozzle. Clean/replace if excessively dirty or damaged - Inspect heat exchangers and check all controls
Every year	<ul style="list-style-type: none"> - Drain fuel tank to remove sediment/water - Service heaters (See "IDF/IDH Heater Maintenance Instructions" in heater manual) - Clean exterior and interior of unit. - Check battery condition & terminals. For extended "off season" idle time, remove battery & maintain charge with a battery maintainer.

RECOMMENDED MAINTENANCE/SERVICE INTERVALS FOR KUBOTA ENGINE	
INTERVAL	ITEM
Every 50 hours	<ul style="list-style-type: none"> - Check engine fuel lines and clamps
Every 100 hours	<ul style="list-style-type: none"> - Clean air filter element - Check belt tension - Drain water separator filter (if applicable)
Every 200 hours	<ul style="list-style-type: none"> - Change engine oil - Inspect radiator hoses & clamps - Inspect air intake hose
Every 400 hours	<ul style="list-style-type: none"> - Replace oil filter - Relace fuel filters or filter cartridges - Clean water separator (if applicable)
Every 500 hours	<ul style="list-style-type: none"> - Remove water/sediment in fuel tank - Replace fan belt - Flush cooling syatem/radiator
Every year	<ul style="list-style-type: none"> - Drain fuel tank - Replace air filter element - Inspect all engine wiring condition & connections
Every 800 hours	<ul style="list-style-type: none"> - Check valve clearance
Every 1500 hours	<ul style="list-style-type: none"> - Check fuel injectors and fuel injection pressure
Every 3000 hours	<ul style="list-style-type: none"> - Check fuel injection pump
Every two years	<ul style="list-style-type: none"> - Replace air intake hose

RECOMMENDED MINIMUM FUEL FILTER REPLACEMENT INTERVALS FOR IDH/IDF OIL FIRED HEATERS

FUEL QUALITY AND OPERATING CONDITIONS	MIN. RECOMMENDED REPLACEMENT INTERVAL
USING FRESH SEASONALLY BLENDED PUMP GRADE DIESEL FUEL	
LIGHT INTERMITTENT USE - 2 to 4 Hours/Day	Change fuel filter element annually
MODERATE INTERMITTENT USE - 6 to 10 Hours/Day	Change fuel filter element at least every 3 to 6 months
HEAVY INTERMITTENT USE - 12 to 16 Hours/Day	Change fuel filter element at least every 2 to 3 months
CONTINUOUS USE - 18 to 24 Hours/Day	Change fuel filter element at least every month
USING OTHER GRADES OF FRESH CLEAN DIESEL FUEL	
LIGHT INTERMITTENT USE - 2 to 4 Hours/Day	Change fuel filter element at least every 3 to 6 months
MODERATE INTERMITTENT USE - 6 to 10 Hours/Day	Change fuel filter element at least every 2 to 3 months
HEAVY INTERMITTENT USE - 12 to 16 Hours/Day	Change fuel filter element at least every month
CONTINUOUS USE - 18 to 24 Hours/Day	Change fuel filter element every 2 to 3 weeks
USING HEAVIER GRADES OF FUEL / LOWER QUALITY FUELS	
LIGHT INTERMITTENT USE - 2 to 4 Hours/Day	Change fuel filter element at least every month
MODERATE INTERMITTENT USE - 6 to 10 Hours/Day	Change fuel filter element every 2 to 3 weeks
HEAVY INTERMITTENT USE - 12 to 16 Hours/Day	Change fuel filter element at least every 2 weeks
CONTINUOUS USE - 18 to 24 Hours/Day	Change fuel filter element weekly

OPERATING TIPS

Ensure only fresh properly graded diesel fuel is used to help prevent fuel related issues. Water can accumulate over time inside of the fuel system and tank from environmental changes especially during storage in the off-season.

A drain is provided at the bottom of the tank for water / fuel removal.

Dispose of any collected water / fuel in the proper manner.

The filters on the heaters should be inspected and changed frequently as dirt and water accumulate in these filters depending on amount of use and quality of fuel used. See "RECOMENDED MINIMUM FUEL FILTER REPLACEMENT INTERVALS" on page 26.

In cold conditions allow the engine a brief warm up period before switching on the heaters. Switch one heater on at a time if possible.

The burners will start first after a pre-purge period and once the heat exchangers are sufficiently warm, the air supply fans will operate. This start time will vary depending on the ambient temperatures and if any residual heat is present in the heat exchanger from a previous heating cycle.

When shutting the heaters down do so only with the "Manual / Off / Thermostat" switch on the heaters. This will allow the proper cool-down period for the heat exchanger as the air supply fans will continue to operate for some time afterwards until the heat exchangers are sufficiently cooled.

DO NOT shut down the generator or turn off the breakers for the heaters until all the fans / motors have stopped.

The diesel engine / generator used in the IDH1000/IDF1000 is a commercial grade continuous duty "Prime Power" unit with a continuous rating of approximately 9 KW. This supplies enough power to operate both heaters as well as provide auxiliary external power to the convenience outlet on the exterior.

For prolonged operation in extreme cold conditions it is advisable to utilize this auxiliary power whenever possible which will add loading to the generator and engine. This will ensure that the engine is sufficiently loaded above 50% capacity and therefore reduce the effects of under-loading or "wet stacking".

This is especially true when only one heater is in use or they will be cycling on / off with a thermostat.

To assist in preventing this, the engine block heater which is plugged into the rear of the control panel can be unplugged and then plugged into the auxiliary outlet on the exterior of the unit. This adds additional electrical load to the generator / engine and also adds some heat into the engine which are both beneficial in preventing "wet stack" conditions.

APPENDIX A

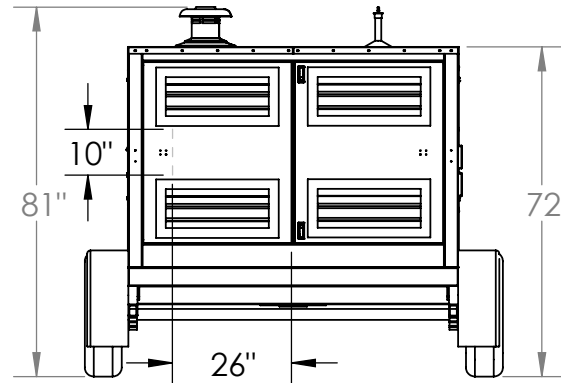
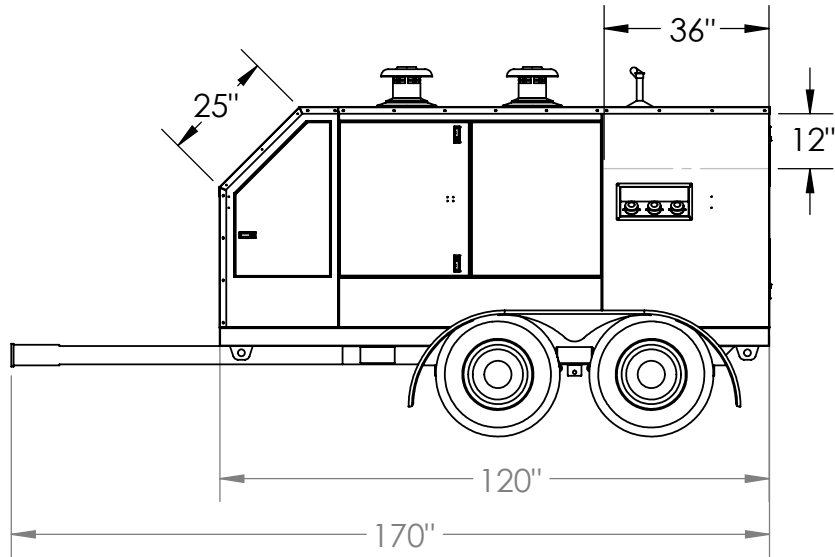
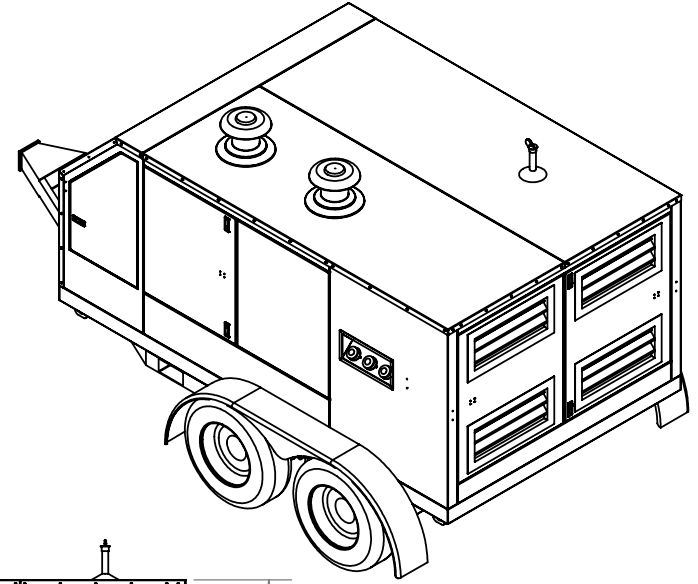
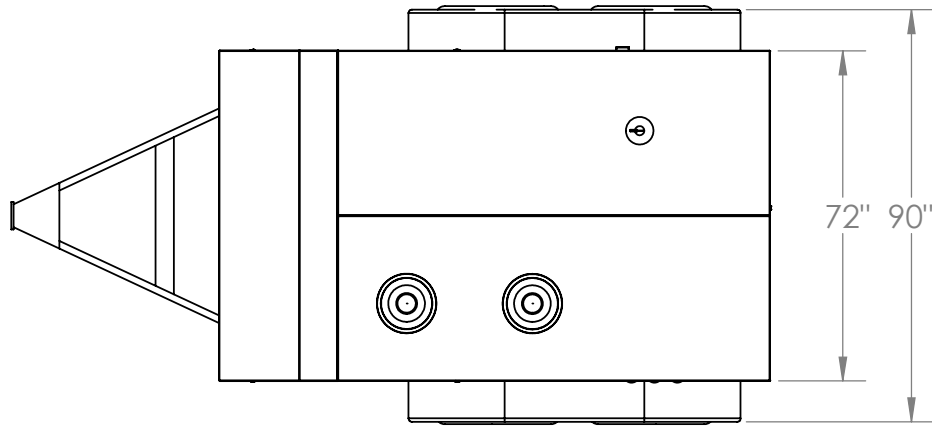

Approx. weight w/o fuel - 4600 lbs. (2090 kg.)
 Approx. weight w/ full fuel - 6380 lbs. (2900 kg.)



100 - 1500 Notre Dame
 Ave Winnipeg, MB R3E 0P9

PROPRIETARY AND CONFIDENTIAL

THE INFORMATION CONTAINED IN THIS DRAWING IS THE SOLE PROPERTY OF FROST FIGHTER. ANY REPRODUCTION IN PART OR AS A WHOLE WITHOUT THE WRITTEN PERMISSION OF FROST FIGHTER IS PROHIBITED.

DRAWING NO.

Trailer Assembly - Dimensions

MODEL: IDF1000 / IDH1000
 FILENAME: N/A
 02/20/2018

DIMENSIONS ARE IN INCHES
 TOLERANCES: FRACTIONAL 1/32